



保存版

**VN1500**

**Drifter**

**VULCAN1500**

**Drifter**

**Motorcycle Owner's Manual**

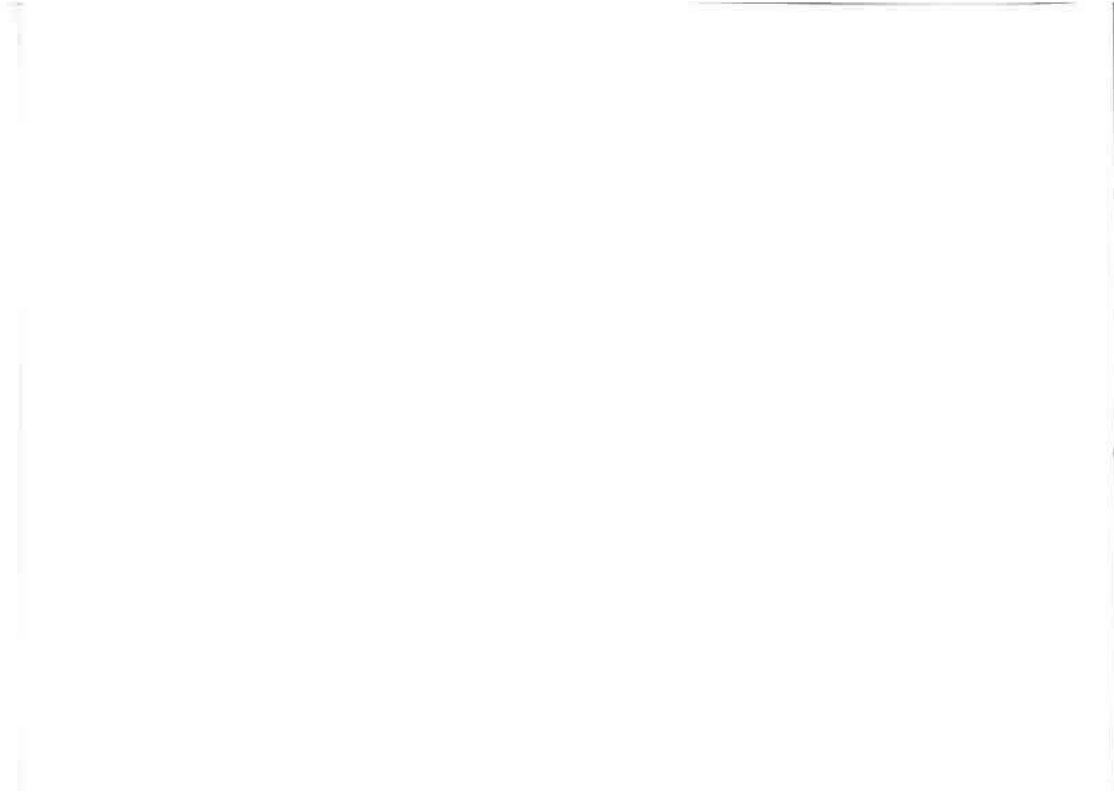

Whenever you see the symbols shown below, heed their instructions! Always follow safe operating and maintenance practices.

**▲WARNING**

**This warning symbol identifies special instructions or procedures which, if not correctly followed, could result in personal injury, or loss of life.**

**CAUTION**

**This caution symbol identifies special instructions or procedures which, if not strictly observed, could result in damage to or destruction of equipment.**

**NOTE**

*○This note symbol indicates points of particular interest for more efficient and convenient operation.*

**NOTICE**

**THIS PRODUCT HAS BEEN MANUFACTURED FOR USE IN A REASONABLE AND PRUDENT MANNER BY A QUALIFIED OPERATOR AND AS A VEHICLE ONLY.**

(Australian model only)

**TAMPERING WITH NOISE CONTROL SYSTEM PROHIBITED**

**Owners are warned that the law may prohibit:**

- (a) The removal or rendering inoperative by any person other than for purposes of maintenance, repair or replacement, of any device or element of design incorporated into any new vehicle for the purpose of noise control prior to its sale or delivery to the ultimate purchaser or while it is in use; and
- (b) the use of the vehicle after such device or element of design has been removed or rendered inoperative by any person.

## FOREWORD

We wish to thank you for choosing this fine Kawasaki Motorcycle. Your new motorcycle is the product of Kawasaki's advanced engineering, exhaustive testing, and continuous striving for superior reliability, safety, and performance.

Read this Owner's Manual before riding so you will be thoroughly familiar with the proper operation of your motorcycle's controls, its features, capabilities and limitations. This manual offers many safe riding tips, but its purpose is not to provide instruction in all the techniques and skills required to ride a motorcycle safely. Kawasaki strongly recommends that all operators of this vehicle enroll in a motorcycle rider training program to attain awareness of the mental and physical requirements necessary for safe motorcycle operation.

To ensure a long, trouble-free life for your motorcycle, give it the proper care and maintenance described in this manual. For those who would like more detailed information on their Kawasaki Motorcycle, a Service Manual is available for purchase from any Kawasaki dealer. The Service Manual contains detailed disassembly and maintenance information.

Due to improvements in design and performance during production, in some cases there may be minor discrepancies between the actual vehicle and the illustrations and text in this manual.

**KAWASAKI HEAVY INDUSTRIES, LTD.**  
**Consumer Products & Machinery Group**



|   |    |
|---|----|
| <b>Safe Operation</b> .....                                 | 45 |
| Daily Safety Checks.....                                    | 45 |
| Additional Considerations for<br>High Speed Operation ..... | 47 |
| <b>Maintenance and Adjustment</b> .....                     | 49 |
| Periodic Maintenance Chart .....                            | 50 |
| Engine Oil.....   | 53 |
| Cooling System.....   | 57 |
| Final Gear Case Oil.....                                    | 62 |
| Spark Plugs.....  | 65 |
| Valve Clearance .....                                       | 66 |
| Kawasaki Clean Air System .....                             | 66 |
| Air Cleaner .....   | 67 |
| Throttle Control System .....                               | 70 |
| Fast Idle.....  | 73 |
| Clutch.....   | 74 |
| Brakes .....  | 76 |
| Brake Light Switches .....                                  | 80 |

|   |                   |
|---|-------------------|
| Rear Shock Absorbers<br>(Other than Australian model) ..... | 81                |
| Wheels.....   | 83                |
| Battery .....   | 86                |
| Headlight Beam .....  | 88                |
| Fuses.....  | 90                |
| Cleaning .....  | 92                |
| <b>Storage</b> .....  | 94                |
| <b>Additional Information</b> .....                         | 97                |
| Rear Shock Absorbers<br>(Australian model only) .....       | 97                |
| <b>Wiring Diagram</b> .....                                 | Inside back cover |





|                     |   |
|---------------------|---|
| Spark Plugs         | NGK DPR6EA-9 or ND X20EPR-U9                            |
| Lubrication System  | Forced Lubrication (wet sump)                           |
| Engine Oil          | SE, SF or SG class SAE 10W40, 10W50,<br>20W40, or 20W50 |
| Engine Oil Capacity | 3.5 L (3.7 US qt)                                       |
| Coolant Capacity    | 2.3 L (2.4 US qt)                                       |

### **TRANSMISSION**

|                              |   |
|------------------------------|---|
| Transmission Type            | 5-speed, constant mesh, return shift                            |
| Clutch Type                  | Wet, multi disc   |
| Driving System               | Shaft drive   |
| Primary Reduction Ratio      | 1.517 (85/56)   |
| Final Reduction Ratio        | 2.619 (15/21 x 33/9)  |
| Overall Drive Ratio          | 3.105 (Top gear)  |
| Gear Ratio: 1st              | 2.500 (40/16)   |
| 2nd                          | 1.590 (35/22)   |
| 3rd                          | 1.192 (31/26)   |
| 4th                          | 0.965 (28/29)   |
| 5th                          | 0.781 (25/32)   |
| Final Gear Case Oil          | API GL-5 SAE 90 [above 5°C (41°F)]<br>SAE 80 [below 5°C (41°F)] |
| Final Gear Case Oil Capacity | 200 mL (0.21 US qt)   |

## FRAME

|                    |       |                         |
|--------------------|-------|-------------------------|
| Castor             |       | 32°                     |
| Trail              |       | 165 mm (6.5 in.)        |
| Tire Size:         | Front | 130/90-16 67H Tube-type |
|                    | Rear  | 150/80B16 71H Tube-type |
| Fuel Tank Capacity |       | 16 L (4.2 US gal)       |

## ELECTRICAL EQUIPMENT

|                  |                 |
|------------------|-----------------|
| Battery          | 12 V 18 Ah      |
| Headlight        | 12 V 60/55 W    |
| Tail/Brake Light | 12 V 5/21 W x 2 |

(A) : Australian model

Specifications subject to change without notice, and may not apply to every country.



- 13. Front Fork
- 14. Headlight
- 15. Turn Signal Light
- 16. Horn
- 17. Radiator Cap
- 18. Spark Plugs
- 19. Battery
- 20. Tying Hook
- 21. Helmet Hook
- 22. Licence Plate Light
- 23. Brake Disc
- 24. Brake Caliper
- 25. Ignition Switch
- 26. Choke Knob
- 27. Radiator
- 28. Shift Pedal
- 29. Side Stand Switch
- 30. Side Stand
- 31. Air Cleaner Element
- 32. Tool Kit Case
- 33. Rear Shock Absorber
- 34. Final Gear Case

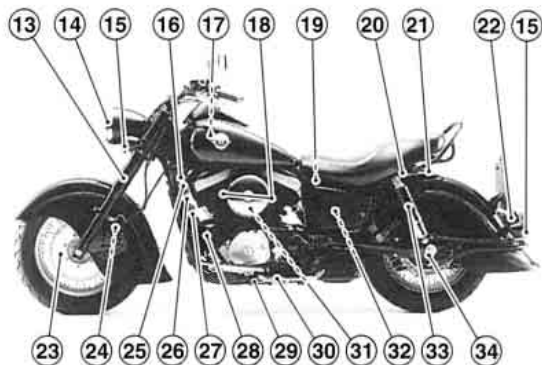

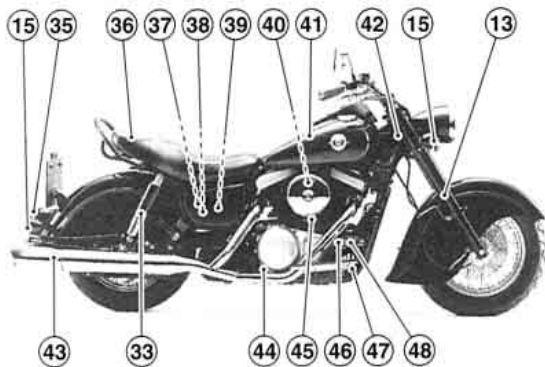

- 35. Tail/Brake Light
- 36. Seat
- 37. Starter Relay
- 38. Junction Box (Fuses)
- 39. Coolant Reserve Tank
- 40. Throttle Body
- 41. Fuel Tank
- 42. Steering Lock
- 43. Muffler
- 44. Oil Level Gauge
- 45. Fast Idle Adjusting  
Screw
- 46. Brake Fluid Reservoir  
(Rear)
- 47. Rear Brake Light Switch
- 48. Rear Brake Pedal





## Speedometer

The speedometer shows the speed of the vehicle. In the speedometer face are the odometer and trip meter. The odometer shows the total distance that the vehicle has been ridden. The trip meter shows the distance traveled since it was last reset to zero. The trip meter can be reset to zero by turning the reset knob counterclockwise.

## Indicator Lights

**N** : When the transmission is in neutral, the neutral indicator light is lit.

 : When the headlight is on high beam, the high beam indicator light is lit.

 : When the turn signal switch is turned to left or right, the turn signal indicator light flashes on and off.

 : The oil pressure warning light goes on whenever the oil pressure is dangerously low or the ignition key is in

the ON position with the engine not running, and goes off when the engine oil pressure is high enough. Refer to the Maintenance and Adjustment chapter for more detailed engine oil information.

 : The coolant temperature warning light goes on when the ignition key is turned to "ON" and goes off soon after ensuring that its circuit functions properly. The warning light also goes on whenever the coolant temperature rises to 120°C or higher when the motorcycle is in operation. If it stays on, stop the engine and check the coolant level in the reserve tank after the engine cools down.

**FI** : The fuel injection (FI) warning light goes on when the ignition key is turned to "ON" and goes off soon after ensuring that its circuit functions properly. The warning light also goes on whenever the troubles occur in digital fuel injection system (DFI). If it turns on, or turns on and off, stop the engine and have the DFI system checked by a compe-

tent mechanic following the procedures in the Service Manual.



The fuel level indicator light goes on when the ignition key is turned to "ON", and goes off soon after ensuring that its circuit functions properly. The indicator light also goes on when the fuel level is low. Refuel at the earliest opportunity if the fuel level indicator light comes on with the engine running.

### **Fuel Gauge**

The fuel gauge shows the amount of fuel in the fuel tank. When the needle comes near the E(empty) position, refuel at the earliest opportunity.

### **Keys**

There are two keys provided except for Australian models. One is for the ignition switch, left side cover lock, helmet hook, and fuel tank cap, and other is for the steering lock.

Blank keys are available at your Kawasaki dealers. Ask your dealer to make any additional spare keys you may need, using your original key as a master.



## Ignition Switch

The ignition switch is located at the left side next to the front cylinder. This is a three-position, key-operated switch. The key can be removed from the switch when it is in the OFF or P(Park) position.

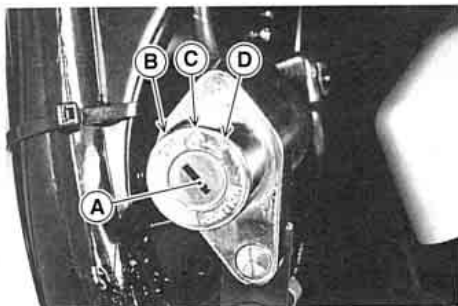

- A. Ignition Switch
- B. OFF
- C. ON
- D. P (Park)

## NOTE

○ *For parking push down the key in the ON position and turn it to P (Park) position.*

|                |  |
|----------------|--|
| <b>OFF</b>     | Engine off. All electrical circuits off.   |
| <b>ON</b>      | Engine on. All electrical equipment can be used.   |
| <b>P(Park)</b> | Engine off. Tail, city (except Australian model) and license plate lights on. All other electrical circuits cut off. |

## NOTE

○ *Australian models only: The tail-light, and license plate light are on whenever the ignition key is in the ON position. The headlight goes on when the starter button is released after starting the engine. To avoid battery discharge, always start the engine im-*

*mediately after turning the ignition key to "ON."*

- *If you leave the P(Park) position on for a long time (one hour), the battery may become totally discharged.*

## **Right Handlebar Switches**

### **Engine Stop Switch**

In addition to the ignition switch, the engine stop switch must be in the  position for the motorcycle to operate.

The engine stop switch is for emergency use. If some emergency requires stopping the engine, move the engine stop switch to the  position.

### **NOTE**

- *Although the engine stop switch stops the engine, it does not turn off all the electrical circuits. Ordinarily, the ignition switch should be used to stop the engine.*

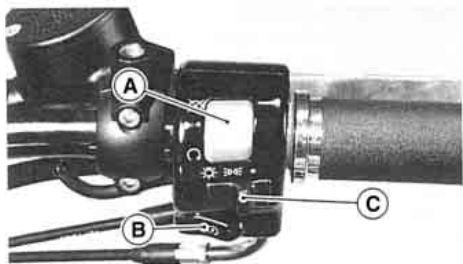

- A. Engine Stop Switch
- B. Starter Button
- C. Headlight Switch

### Starter Button

The starter button operates the electric starter when pushed with the clutch lever pulled in or the transmission in neutral.

Refer to the Starting the Engine section of the "How to Ride the Motorcycle" chapter for starting instructions.

### Headlight Switch

(except Australian models)

|    |   |
|----|---|
| ○  | Headlight off.  |
| ☞☛ | City, tail, license plate, and meter lights on with ignition key in ON position.      |
| ☀  | Head, city, tail, license plate, and meter lights on with ignition key in ON position |

## Left Handlebar Switches

### Dimmer Switch

High or low beam can be selected with the dimmer switch. When the headlight is on high beam (  ), the high beam indicator light is lit.

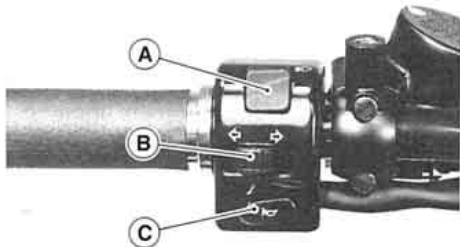

High beam ..... (  )

Low beam ..... (  )



- A. Dimmer Switch
- B. Turn Signal Switch
- C. Horn Button

### Turn Signal Switch

When the turn signal switch is turned to the left (  ) or right (  ), the corresponding turn signals flash on and off.

The turn signal switch is automatically canceled after it has first been on for 8 seconds, and then the motorcycle has traveled an additional 65 m (213 ft). However, make a practice of pushing the switch in to stop flashing.

### Horn Button

When the horn button is pushed, the horn sounds.

## Brake/Clutch Lever Adjusters

There is an adjuster on both the brake and clutch levers. Each adjuster has 5 positions so that the released lever position can be adjusted to suit the operator's hands. Push the lever forward and turn the adjuster to align the number with the arrow mark on the lever holder. The distance from the grip to the released lever is minimum at Number 5 and maximum at Number 1.

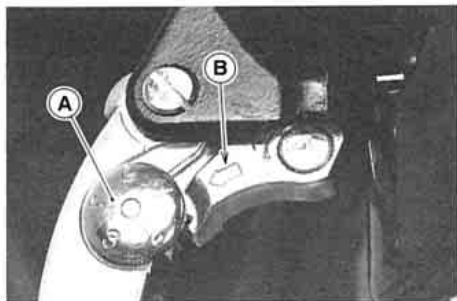

A. Adjuster

B. Arrow

## Fuel Tank Cap

To open the fuel tank cap, insert the ignition key into the fuel tank cap and turn the key to the right.

To close the cap, push it down into place with the key inserted. The key can be removed by turning it to the left to the original position.

### NOTE

- *The fuel tank cap cannot be closed without the key inserted, and the key cannot be removed unless the cap is locked properly.*
- *Do not push on the key to close the cap, or the cap cannot be locked.*

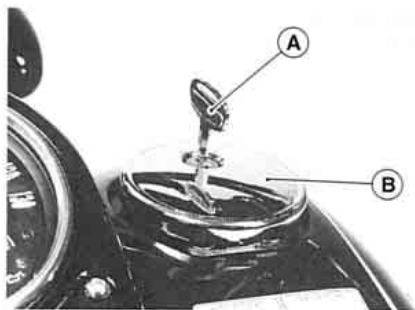

A. Ignition Key  
B. Fuel Tank Cap

## Fuel Tank

Avoid filling the tank in the rain or where heavy dust is blowing so that the fuel does not get contaminated.

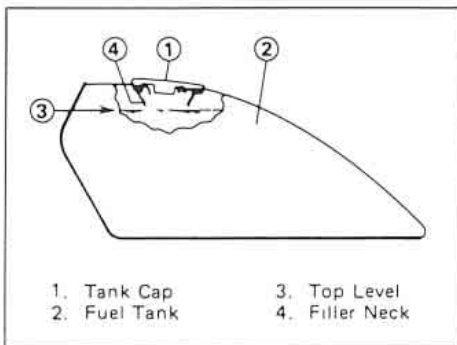

## ▲WARNING

**Gasoline is extremely flammable and can be explosive under certain conditions. Turn the ignition key to "OFF." Do not smoke. Make sure the area is well ventilated and free from any source of flame or sparks; this includes any appliance with a pilot light. Never fill the tank so the fuel level rises into the filler neck. If the tank is overfilled, heat may cause the fuel to expand and overflow through the vents in the tank cap.**

**After refueling, make sure the fuel tank cap is closed securely.**

**If gasoline is spilled on the fuel tank, wipe it off immediately.**

**Fuel Requirement:**

Your Kawasaki engine is designed to use unleaded gasoline. However, except for Australian models, if suitable gasoline is not available then PREMIUM, SUPER, or FOUR-STAR gasolines may be used.

**CAUTION**

**Use of leaded gasoline is illegal in some countries, states or territories. Check local regulations before using leaded gasoline.**

**CAUTION**

**Use minimum of 95 octane gasoline only to prevent severe engine damage.**

**NOTE**

*○ If "knocking" or "pinging" occurs, use a different brand of gasoline or higher octane rating.*

*Octane Rating*

The octane rating of a gasoline is a measure of its resistance to detonation or "knocking." The term commonly used to describe a gasoline's octane rating is the Research Octane Number (RON). Always use a gasoline with an octane rating equal to, or higher than, RON 95.



## Stand

The motorcycle is equipped with a side stand.

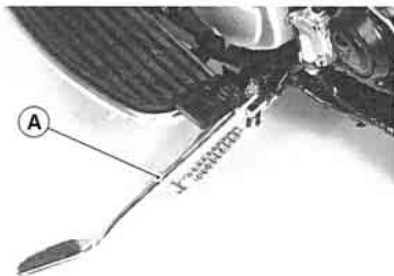

### A. Side Stand

## NOTE

- *When using the side stand, turn the handlebar to the left.*

Whenever the side stand is used, make it a practice to kick the stand fully up before sitting on the motorcycle.

## NOTE

- *The motorcycle is equipped with a side stand switch. This switch is designed so that the engine stops if the clutch is engaged with the transmission in gear when the side stand is left down.*

## Seat

Take off the locknut of the seat rear end, and the seat mounting bolt of the left and right side and then pull the seat up.

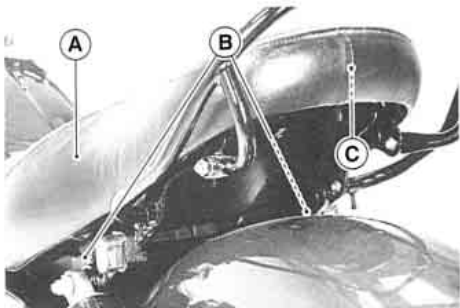

- A. Seat
- B. Seat Mounting Bolt
- C. Locknut

## Side Covers

The left and right side covers are removed for refilling the coolant and taking out the tool kit.

### Right Side Cover Removal:

1. Remove the right side cover mounting screw.
2. Pull the side cover outward.



A. Right Side Cover

B. Screw

### Left Side Cover Removal:

1. Insert the ignition key into the lock, and turn the key to the right.
2. Pull the side cover rear end outward.
3. Push the side cover toward the front with the ignition key inserted.

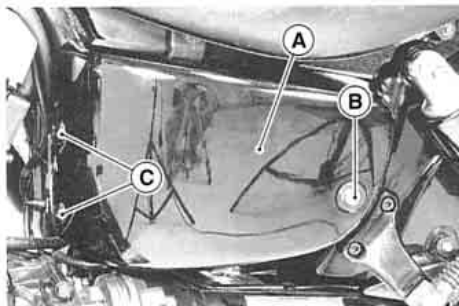

A. Left Side Cover  
B. Lock

C. Projections

### Tool Kit Case

The tool kit case is located behind the left side cover.

The tool kit case is removed when pulling it outward. The tool kit is kept inside this case. The minor adjustments and replacement of parts explained in this manual can be performed with the tools in the kit.

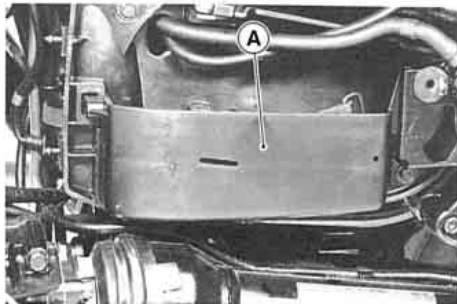

A. Tool Kit Case

## Tying Hooks

When tying up light loads to the seat, use the tying hook on the left and right side under the seat.

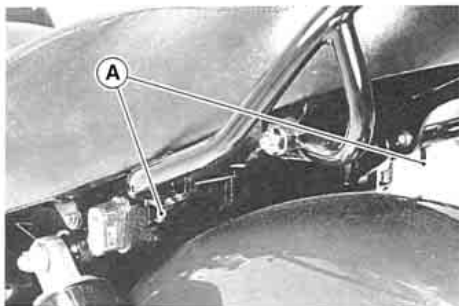

A. Tying Hook

## Helmet Hooks

Helmets can be secured to the motorcycle using the helmet hooks.

The helmet hook can be unlocked by inserting the ignition key into the lock, and turning the key to the right.

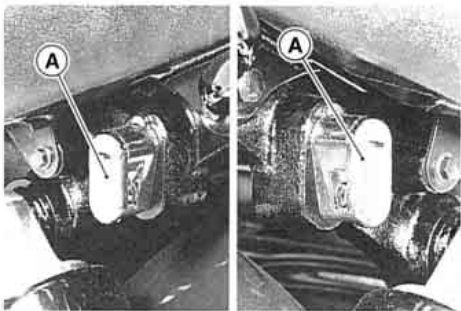

A. Helmet Hooks

**▲WARNING**

**Do not ride the motorcycle with helmets attached to the hooks. The helmets could cause an accident by distracting the operator or interfering with normal vehicle operation.**

## **Steering Lock**

The motorcycle is equipped with the steering lock at the right side of the head pipe.

### **To lock the steering:**

1. Turn the handlebar to the left.
2. Push open the key hole cover counter-clockwise (clockwise for Australian models).
3. Insert the steering lock key (ignition key for Australian models).
4. Turn the key to the left.
5. Push the key in turning the handlebar slightly to the right, and turn the key to the right.
6. Pull the key out.

**▲WARNING**

**Unlock the steering before starting the engine. Attempting to drive with the steering locked could cause an accident.**

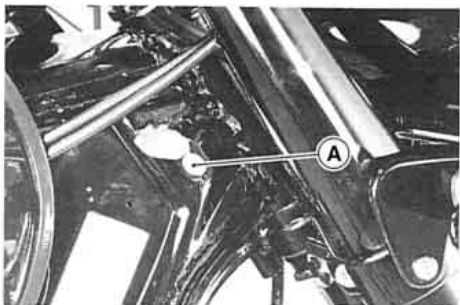

**A. Steering Lock**

## Electric Accessory Connectors

The electric power of the battery can be used through the electric accessory connectors regardless of ignition switch position. Observe and follow the notes listed below.

| Location                | Polarity | Wire Color   |
|-------------------------|----------|--------------|
| Under Seat              | (+)      | White/Blue   |
|                         | (-)      | Black/yellow |
| Under Meter Instruments | (+)      | White/Blue   |
|                         | (-)      | Black/Yellow |
| Maximum Current :       |          | 10A          |

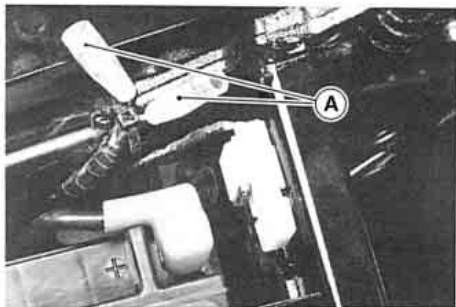

**A. Electric Accessory Connectors**

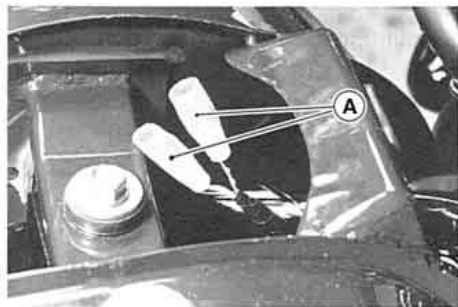

**A. Electric Accessory Connectors**

- To remove the meter unit, take off the mounting bolt, and then pull up the meter unit.



A. Meter Unit

B. Mounting Bolt

### CAUTION

Always install a 10A fuse or less in the electrical accessory circuit. The vehicle has one fuse (10A) to protect the electrical system. If this fuse fails, the engine will not run.

Do not connect more than a 30 W total load to the vehicle's electrical system or the battery may become discharged. This is with the engine running.

If a current of 20 amperes is continuously taken out with the engine stopped, even an originally-fully-charged battery may become totally discharged in about 20 minutes.

Whenever you leave the vehicle, turn off all electrical accessories.

### ▲ WARNING

Take care not to pinch any wire between the seat and the frame or between other parts to avoid a short circuit.





**▲WARNING**

**New tires are slippery and may cause loss of control and injury.  
A break-in period of 160 km (100 miles) is necessary to establish normal tire traction.  
During break-in, avoid sudden and maximum braking and acceleration, and hard cornering.**

In addition to the above, at 1,000 km (600 mi) it is extremely important that the owner have the initial maintenance service performed by an authorized Kawasaki dealer.



- Make certain the transmission is in neutral.



**A. Neutral Indicator Light**

- Leaving the throttle completely closed, push the starter button without using the choke knob.

### CAUTION

Do not operate the starter continuously for more than 5 seconds, or the starter will overheat and the battery power will drop temporarily. Wait 15 seconds between each operation of the starter to let it cool and the battery power recover.

### NOTE

- *Pull the choke knob to ease starting in cold weather or at high altitude.*

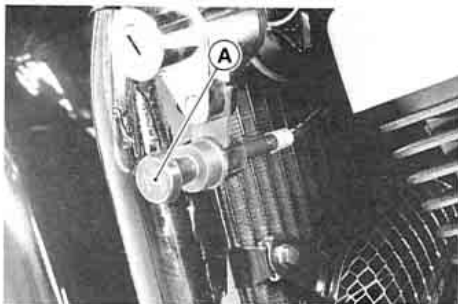

A. Choke Knob

### NOTE

- If the engine is flooded, crank the engine over with the throttle fully open until the engine starts.
- The motorcycle is equipped with a starter lockout switch. This switch prevents the electric starter from operating when the clutch is engaged and the transmission is not in neutral.

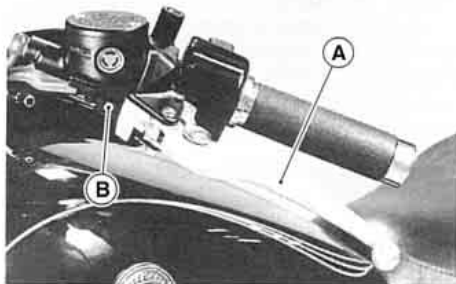

A. Clutch Lever  
B. Starter Lockout Switch

### CAUTION

Do not let the engine idle longer than five minutes, or engine overheating and damage may occur.

## Jump Starting

If your motorcycle battery is "run down," it should be removed and charged. If this is not practical, a 12 volt booster battery and jumper cables may be used to start the engine.

### **▲WARNING**

Battery acid generates hydrogen gas which is flammable and explosive under certain conditions. It is present within a battery at all times, even in a discharged condition. Keep all flames and sparks (cigarettes) away from the battery. Wear eye protection when working with a battery. In the event of battery acid contact with skin, eyes, or clothing, wash the affected areas immediately with water for at least five minutes. Seek medical attention.

### *Connecting Jumper Cables*

- Remove the seat. (see Seat section in General Information chapter.)
- Make sure the ignition key is turned to "OFF."
- Connect a jumper cable from the positive (+) terminal of the booster battery to the positive (+) terminal of the motorcycle battery.

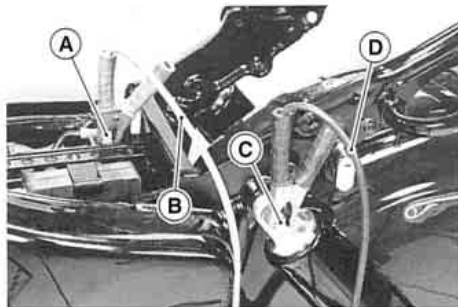

- A. Motorcycle Battery Positive (+) Terminal
- B. From Booster Battery Positive (+) Terminal
- C. Unpainted Metal Surface
- D. From Booster Battery Negative (-) Terminal

- Connect another jumper cable from the negative (-) terminal of the booster battery to the upper end of the rear shock absorber of your motorcycle or other unpainted metal surface. Do not use the negative (-) terminal of the battery.

#### **▲WARNING**

**Do not make this last connection at the cylinder head cover or battery. Take care that you do not touch the positive and negative cables together, and do not lean over the battery when making this last connection. Do not jump start a frozen battery. It could explode. Do not reverse polarity by connecting positive (+) to negative (-), or a battery explosion and serious damage to the electrical system may occur.**

- Follow the standard engine starting procedure.

#### **CAUTION**

**Do not operate the starter continuously for more than 5 seconds or the starter will overheat and the battery power will drop temporarily. Wait 15 seconds between each operation of the starter to let it cool and the battery power recover.**

- After the engine has started disconnect the jumper cables. Disconnect the negative (-) cable from the motorcycle first.
- Reinstall the seat.

## Moving Off

- Check that the side stand is up.
- Pull in the clutch lever.
- Shift into 1st gear.
- Open the throttle a little, and start to let out the clutch lever very slowly.
- As the clutch starts to engage, open the throttle a little more, giving the engine just enough fuel to keep it from stalling.

## NOTE

- *The motorcycle is equipped with a side stand switch. This switch is designed so that the engine stops if the clutch is engaged with the transmission in gear when the side stand is left down.*

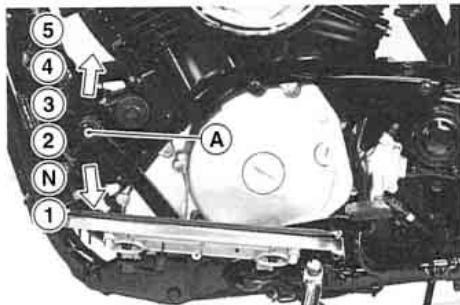

A. Shift Pedal



## Shifting Gears

- Close the throttle while pulling in the clutch lever.
- Shift into the next higher or lower gear.

### ⚠ WARNING

When shifting down to a lower gear, do not shift at such a high speed that the engine r/min (rpm) jumps excessively. Not only can this cause engine damage, but the rear wheel may skid and cause an accident. Downshifting should be done below the vehicle speeds shown in the table.

- Open the throttle part way, while releasing the clutch lever.

|           | km/h (mph) |
|-----------|------------|
| 5th → 4th | 50 (31)    |
| 4th → 3rd | 40 (25)    |
| 3rd → 2nd | 30 (19)    |
| 2nd → 1st | 20 (13)    |

### NOTE

- *The transmission is equipped with a positive neutral finder. When the motorcycle is standing still, the transmission cannot be shifted past neutral from 1st gear. To use the positive neutral finder, shift down to 1st gear, then lift up on the shift pedal while standing still. The transmission will shift only into neutral.*

## Braking

- Close the throttle completely, leaving the clutch engaged (except when shifting gears) so that the engine will help slow down the motorcycle.
- Shift down one gear at a time so that you are in 1st gear when you come to a complete stop.
- When stopping, always apply both brakes at the same time. Normally the front brake should be applied a little more than the rear. Shift down or fully disengage the clutch as necessary to keep the engine from stalling.
- Never lock the brakes, or it will cause the tires to skid. When turning a corner, it is better not to brake at all. Reduce your speed before you get into the corner.
- For emergency braking, disregard downshifting, and concentrate on applying the brakes as hard as possible without skidding.

## CAUTION

**In order to protect the Kawasaki clean air system parts, do not turn off the ignition switch when the motorcycle is in motion.**

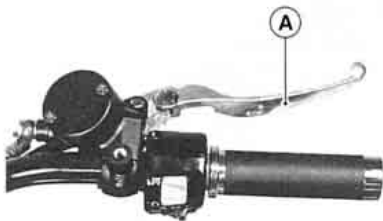

**A. Front Brake Lever**



**A. Rear Brake Pedal**

### **Stopping the Engine**

- Close the throttle completely.
- Shift the transmission into neutral.
- Turn the ignition key to "OFF."
- Support the motorcycle on a firm, level surface with the side stand.
- Lock the steering.

### **NOTE**

- *The motorcycle is equipped with a vehicle-down sensor, which causes the engine to stop automatically when the motorcycle falls down. After righting the motorcycle, first turn the ignition key to "OFF" and then back to "ON" before starting the engine.*

## **Stopping the Motorcycle in an Emergency**

Your Kawasaki Motorcycle has been designed and manufactured to provide you optimum safety and convenience. However, in order to fully benefit from Kawasaki's safety engineering and craftsmanship, it is essential that you, the owner and operator, properly maintain your motorcycle and become thoroughly familiar with its operation. Improper maintenance can create a dangerous situation known as throttle failure. Two of the most common causes of throttle failure are:

1. An improperly serviced or clogged air cleaner may allow dirt and dust to enter the butterfly valve and stick the throttle open.
2. During removal of the air cleaner, dirt is allowed to enter and jam the butterfly valve.

In an emergency situation such as throttle failure, your vehicle may be stopped by applying the brakes and dis-

engaging the clutch. Once this stopping procedure is initiated, the engine stop switch may be used to stop the engine. If the engine stop switch is used, turn off the ignition switch after stopping the motorcycle.

## Parking

- Shift the transmission into neutral and turn the ignition key to "OFF."
- Support the motorcycle on a firm, level surface with the side stand.

### CAUTION

**Do not park on a soft or steeply inclined surface, or the motorcycle may fall over.**

- If parking inside a garage or other structure, be sure it is well ventilated and the motorcycle is not close to any source of flame or sparks; this includes any appliance with a pilot light.

### ⚠WARNING

**Gasoline is extremely flammable and can be explosive under certain conditions.**

- Lock the steering to help prevent theft.

### NOTE

- *When stopping near traffic at night, you can leave the taillight, license plate light and city light (except Australian models) on for greater visibility by turning the ignition key to the P(Park) position.*
- *Do not leave the ignition switch at P position too long, or the battery will discharge.*

## Catalytic Converter

This motorcycle is equipped with a catalytic converter in the exhaust system. Platinum and rhodium in the converter react with harmful carbon monoxide and hydrocarbons to convert them into harmless carbon dioxide and water resulting in much cleaner exhaust gases to be discharged into the atmosphere.

For proper operation of the catalytic converter, the following cautions must be observed.

- Use only unleaded gasoline. Never use leaded gasoline. Leaded gasoline significantly reduces the capability of the catalytic converter.
- Do not coast the vehicle with the ignition switch and/or engine stop switch off. Do not attempt to start the engine by rolling the vehicle if the battery is discharged. Do not operate the vehicle with the engine or any one cylinder misfiring. Under these conditions unburned air/fuel mixture flowing out of engine excessively

accelerates reaction in the converter allowing the converter to overheat and become damaged when the engine is hot, or reduces converter performance when the engine is cold.



|                              |   |
|------------------------------|---|
| Nuts, bolts, fasteners ..... | Check that steering and suspension components, axles, and all controls are properly tightened or fastened |
| Steering .....               | Action smooth but not loose from lock to lock. No binding of control cables                               |
| Brakes .....                 | Brake pad wear: Lining thickness more than 1 mm (0.04 in.) left   |
|                              | No brake fluid leakage  |
| Throttle .....               | Throttle grip play 2 ~ 3 mm (0.08 ~ 0.12 in.)   |
| Clutch .....                 | No clutch fluid leakage   |
| Coolant.....                 | No coolant leakage  |
|                              | Coolant level between level lines (when engine is cold)   |
| Final gear case.....         | No oil leakage  |
| Electrical equipment.....    | All lights and horn work  |
| Engine stop switch.....      | Stop engine   |
| Side stand .....             | Return to its fully up position by spring tension   |
|                              | Return spring not weak or not damaged   |

Refer to the "Daily Safety Checks" caution label attached to the back of the left side cover.



## Additional Considerations for High Speed Operation

### ▲WARNING

**Handling characteristics of a motorcycle at high speeds may vary from those you are familiar with at legal highway speeds. Do not attempt high speed operation unless you have received sufficient training and have the required skills.**

**Brakes:** The importance of the brakes, especially during high speed operation, cannot be overemphasized. Check to see that they are correctly adjusted and functioning properly.

**Steering:** Looseness in the steering can cause loss of control. Check to see that the handlebar turns freely but has no play.

**Tires:** High speed operation is hard on tires, and good tires are crucial for riding safety. Examine their overall condition, inflate them to the proper pressure, and check the wheel balance.

**Spark Plugs:** For demanding operation such as racing, install spark plugs with one heat colder range NGK DPR7EA-9 or ND X22EPR-U9.

**Fuel:** Have sufficient fuel for high fuel consumption during high speed operation.

**Engine Oil:** To avoid engine seizure and resulting loss of control, make certain that the oil level is at the upper level line.

**Coolant:** To avoid overheating, check that the coolant level is at the upper level line.

**Final Gear Case Oil :** To avoid seizure and resulting loss of control, make certain the oil level is correct.

**Electrical Equipment:** Make certain that the headlight, tail/brake light, turn signals, horn, etc., all work properly.

**Miscellaneous:** Make certain that all nuts and bolts are tight and that all safety related parts are in good condition.



## Periodic Maintenance Chart

| Operation                          | Frequency                           | *Odometer Reading km(mi) |                  |                   |                    |                    |                    |                    | See Page |
|------------------------------------|-------------------------------------|--------------------------|------------------|-------------------|--------------------|--------------------|--------------------|--------------------|----------|
|                                    | Whichever comes first<br>↓<br>Every | 1,000<br>(600)           | 6,000<br>(4,000) | 12,000<br>(7,500) | 18,000<br>(12,000) | 24,000<br>(15,000) | 30,000<br>(20,000) | 36,000<br>(24,000) |          |
| Fast Idle-check †                  |                                     | ●                        |                  | ●                 |                    | ●                  |                    | ●                  | 73       |
| Throttle control system-check †    |                                     | ●                        | ●                | ●                 | ●                  | ●                  | ●                  | ●                  | 70       |
| Spark plug-clean and gap †         |                                     |                          | ●                | ●                 | ●                  | ●                  | ●                  | ●                  | 65       |
| <b>K</b> Air suction valve-check † |                                     |                          | ●                | ●                 | ●                  | ●                  | ●                  | ●                  | 66       |
| Air cleaner element-clean †#       |                                     |                          |                  | ●                 |                    | ●                  |                    | ●                  | 67       |
| Brake light switch-check †         |                                     | ●                        | ●                | ●                 | ●                  | ●                  | ●                  | ●                  | 80       |
| Brake pad wear-check †#            |                                     |                          | ●                | ●                 | ●                  | ●                  | ●                  | ●                  | 76       |
| Brake/clutch fluid level-check †   | month                               | ●                        | ●                | ●                 | ●                  | ●                  | ●                  | ●                  | 77,74    |
| <b>K</b> Brake/clutch fluid-change | 2 years                             |                          |                  |                   |                    | ●                  |                    |                    | 79,74    |
| <b>K</b> Steering-check †          |                                     | ●                        | ●                | ●                 | ●                  | ●                  | ●                  | ●                  | -        |

| Operation   | Frequency                   | *Odometer Reading km(mi) |                  |                   |                    |                    |                    |                    | See Page |
|---|-----------------------------|--------------------------|------------------|-------------------|--------------------|--------------------|--------------------|--------------------|----------|
|   | Which ever comes first<br>↓ | 1,000<br>(600)           | 6,000<br>(4,000) | 12,000<br>(7,500) | 18,000<br>(12,000) | 24,000<br>(15,000) | 30,000<br>(20,000) | 36,000<br>(24,000) |          |
|   | Every                       |                          |                  |                   |                    |                    |                    |                    |          |
| Final gear case oil level-check †                   |                             |                          |                  | ●                 |                    | ●                  |                    | ●                  | 62       |
| Final gear case oil-change                          |                             | ●                        |                  |                   |                    |                    |                    | ●                  | 63       |
| <b>K</b> Propeller shaft joint-lubricate            |                             |                          |                  | ●                 |                    |                    |                    | ●                  | -        |
| Nut, bolt, fastener tightness<br>-check †           |                             | ●                        |                  | ●                 |                    | ●                  |                    | ●                  | -        |
| <b>K</b> Spoke tightness and rim runout<br>-check † |                             | ●                        | ●                | ●                 | ●                  | ●                  | ●                  | ●                  | -        |
| Tire wear-check †                                   |                             |                          | ●                | ●                 | ●                  | ●                  | ●                  | ●                  | 84       |
| Engine oil-change #                                 | 6 months                    | ●                        | ●                | ●                 | ●                  | ●                  | ●                  | ●                  | 55       |
| Oil filter-replace                                  |                             | ●                        |                  | ●                 |                    | ●                  |                    | ●                  | 55       |
| General lubrication-perform                         |                             |                          |                  | ●                 |                    | ●                  |                    | ●                  | -        |
| <b>K</b> Front fork oil-change                      | 2 years                     |                          |                  |                   |                    | ●                  |                    |                    | -        |
| Front fork oil leak-check †                         |                             |                          |                  | ●                 |                    | ●                  |                    | ●                  | -        |
| Rear shock absorber oil leak<br>-check †            |                             |                          |                  | ●                 |                    | ●                  |                    | ●                  | -        |

| Operation   | Frequency | Whichever comes first<br>↓ | *Odometer Reading km(mi) |                |                  |                   |                    |                    |                    | See Page |                    |
|---|-----------|----------------------------|--------------------------|----------------|------------------|-------------------|--------------------|--------------------|--------------------|----------|--------------------|
|   |           |                            | Every                    | 1,000<br>(600) | 6,000<br>(4,000) | 12,000<br>(7,500) | 18,000<br>(12,000) | 24,000<br>(15,000) | 30,000<br>(20,000) |          | 36,000<br>(24,000) |
| K Swingarm pivot-lubricate                                  |           |                            |                          |                | ●                |                   |                    | ●                  |                    | ●        | -                  |
| K Coolant-change  | 2 years   |                            |                          |                |                  |                   |                    | ●                  |                    |          | 61                 |
| Radiator hoses, connections<br>-check †                     |           |                            | ●                        |                |                  |                   |                    |                    |                    |          | 58                 |
| K Steering stem bearing-lubricate                           | 2 years   |                            |                          |                |                  |                   |                    | ●                  |                    |          | -                  |
| K Brake/clutch master cylinder<br>cup and dust seal-replace | 4 years   |                            |                          |                |                  |                   |                    |                    |                    |          | -                  |
| K Caliper piston seal and dust<br>seal-replace              | 4 years   |                            |                          |                |                  |                   |                    |                    |                    |          | -                  |
| K Clutch slave cylinder piston<br>seal-replace              | 4 years   |                            |                          |                |                  |                   |                    |                    |                    |          | -                  |

**K** : Should be serviced by an authorized Kawasaki dealer.

\* : For higher odometer readings, repeat at the frequency interval established here.

† : Replace, add, adjust, or torque if necessary.

# : Service more frequently when operating in severe conditions: dusty, wet, muddy, high speed, or frequent starting/stopping.

## Engine Oil

In order for the engine, transmission, and clutch to function properly, maintain the engine oil at the proper level, and change the oil and replace the oil filter in accordance with the Periodic Maintenance Chart. Not only do dirt and metal particles collect in the oil, but the oil itself loses its lubricative quality if used too long.

### **▲WARNING**

**Motorcycle operation with insufficient, deteriorated, or contaminated engine oil will cause accelerated wear and may result in engine or transmission seizure, accident, and injury.**

### *Oil Level Inspection*

- If the oil has just been changed, start the engine and run it for several minutes at idle speed. This fills the oil filter with oil. Stop the engine, then wait several minutes until the oil settles.

### **CAUTION**

**Racing the engine before the oil reaches every part can cause engine seizure.**

- If the motorcycle has just been used, wait several minutes for all the oil to drain down.
- Check the engine oil level through the oil level gauge. With the motorcycle held level, the oil level should come up between the High and Low level lines next to the gauge.

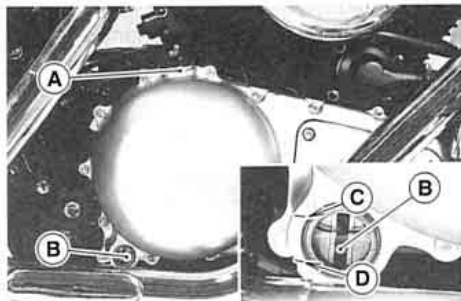

**A. Oil Filler Cap      C. High Level Line**  
**B. Oil Level Gauge    D. Low Level Line**

- If the oil level is too high, remove the excess oil through the oil filler opening using a syringe or some other suitable device.
- If the oil level is too low, add the oil to reach the correct level. Use the same type and brand of oil that is already in the engine.

## CAUTION

If the engine oil gets extremely low or if the oil pump does not function properly or oil passages are clogged, the oil pressure warning light will light. If this light stays on when the engine is running slightly above the idle speed, stop the engine immediately and find the cause.



**A. Oil Pressure Warning Light**



### *Oil and/or Oil Filter Change*

- Warm up the engine thoroughly, and then stop it.
- Place an oil pan beneath the engine.
- Remove the engine oil drain plug.

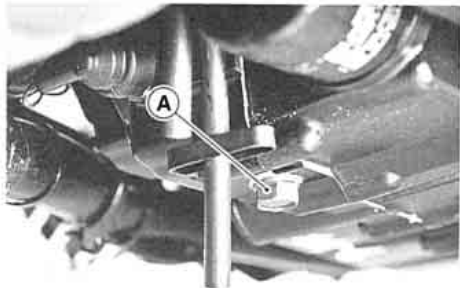

#### **A. Drain Plug**

- Let the oil completely drain with the motorcycle perpendicular to the ground.

### **⚠ WARNING**

**Motor oil is a toxic substance. Dispose of used oil properly. Contact your local authorities for approved disposal methods or possible recycling.**

- If the oil filter is to be replaced remove the oil filter cartridge and replace it with a new one.

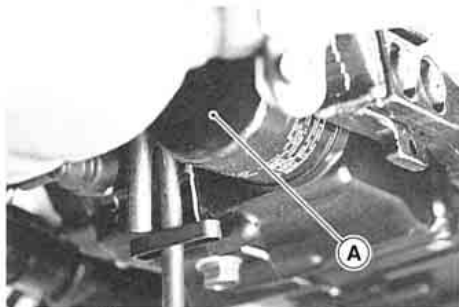

#### **A. Cartridge**

- Apply a thin film of oil to the packing and tighten the cartridge to the specified torque.



#### A. Packing

- Install the drain plug with its gasket and tighten it to the specified torque.

## NOTE

- *Replace the damaged gasket with a new one.*
- Fill the engine up to the upper level line with a good quality engine oil specified in the table.
- Check the oil level.
- Start the engine and check for oil leakage.

#### Tightening Torque

Engine Oil Drain Plug:

20 N-m (2.0 kg-m, 14.5 ft-lb)

Cartridge:

15 ~ 20 N-m (1.5 ~ 2.0 kg-m,

11.0 ~ 14.5 ft-lb)

## Engine Oil

Grade: SE, SF or SG class  
Viscosity: SAE 10W40, 10W50,  
20W40, or 20W50  
Capacity: 2.9 L (3.0 US qt)  
[when filter is not removed]  
3.1 L (3.2 US qt)  
[when filter is removed]  
3.5 L (3.7 US qt)  
[when engine is completely  
dry]

## Cooling System

### Radiator and Cooling Fan:

Check the radiator fins for obstruction by insects or mud. Clean off any obstructions with a stream of low-pressure water.

### WARNING

**The cooling fan turns on automatically, even with the ignition switch off. Keep your hands and clothing away from the fan blades at all times.**

## CAUTION

Using high-pressure water, as from a car wash facility, could damage the radiator fins and impair the radiator's effectiveness.

Do not obstruct or deflect airflow through the radiator by installing unauthorized accessories in front of the radiator or behind the cooling fan. Interference with the radiator airflow can lead to overheating and consequent engine damage.

### Radiator Hoses:

Check the radiator hoses for cracks or deterioration, and connections for looseness in accordance with the Periodic Maintenance Chart.

### Coolant:

Coolant absorbs excessive heat from the engine and transfers it to the air at the radiator. If the coolant level becomes low, the engine overheats and may suffer severe damage. Check the coolant level each day before riding the motorcycle, and replenish coolant if the level is low. Change the coolant in accordance with the Periodic Maintenance Chart.

### *Information for Coolant*

To protect the cooling system (consisting of the aluminum engine and radiator) from rust and corrosion, the use of corrosion and rust inhibitor chemicals in the coolant is essential. If coolant containing corrosion and rust inhibitor chemicals is not used, over a period of time, the cooling system accumulates rust and scale in the water jacket and radiator. This will clog up the coolant passages, and considerably reduce the efficiency of the cooling system.

**▲ WARNING**

**Use coolant containing corrosion inhibitors made specifically for aluminum engines and radiators in accordance with the instructions of the manufacturer. Chemicals are harmful to the human body.**

Soft or distilled water must be used with the antifreeze (see below for antifreeze) in the cooling system.

**CAUTION**

**If hard water is used in the system, it causes scale accumulation in the water passages, and considerably reduces the efficiency of the cooling system.**

If the lowest ambient temperature encountered falls below the freezing point of water, use permanent antifreeze in the coolant to protect the cooling system

against engine and radiator freeze-up, as well as from rust and corrosion.

Use a permanent type of antifreeze (soft water and ethylene glycol plus corrosion and rust inhibitor chemicals for aluminum engines and radiators) in the cooling system. On the mixture ratio of coolant, choose the suitable one referring to the relation between freezing point and strength directed on the container.

**CAUTION**

**Permanent types of antifreeze on the market have anti-corrosion and anti-rust properties. When it is diluted excessively, it loses its anti-corrosion property. Dilute a permanent type of antifreeze in accordance with the instructions of the manufacturer.**

## NOTE

- A permanent type of antifreeze is installed in the cooling system when shipped. It is colored green and contains ethylene glycol. It is mixed at 50% and has the freezing point of  $-35^{\circ}\text{C}$  ( $-31^{\circ}\text{F}$ ).

### Coolant Level Inspection

- Situate the motorcycle so that it is perpendicular to the ground.
- Check the coolant level through the coolant level gauge. The coolant level should be between the F(FULL) and L(LOW) marks.

## NOTE

- Check the level when the engine is cold (room or atmospheric temperature).

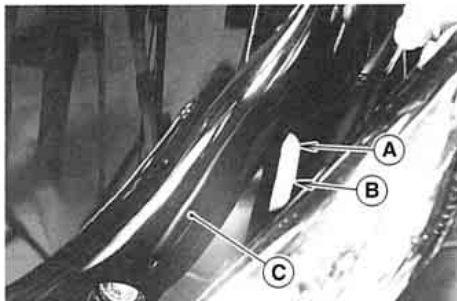

A. F(FULL) Mark  
B. L(LOW) Mark  
C. Right Side Cover

- If the amount of coolant is insufficient, remove the right side cover, pull open the cap from the reserve tank and add coolant through the filler opening to the F(Full) mark.

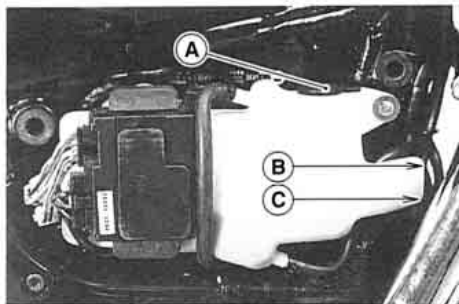

A. Cap

B. F(Full) Mark

C. L(Low) Mark

- Install the cap and right side cover.

## NOTE

- *In an emergency you can add water alone to the coolant reserve tank, however it must be returned to the correct mixture ratio by the addition of antifreeze concentrate as soon as possible.*

## CAUTION

If coolant must be added often, or the reserve tank completely runs dry, there is probably leakage in the system. Have the cooling system inspected by your authorized Kawasaki dealer.

### *Coolant Change*

Have the coolant changed by an authorized Kawasaki dealer.

## Final Gear Case Oil

In order for the pinion and ring gears in the final gear case to function properly, check the oil level, and change the oil in accordance with the Periodic Maintenance Chart.

### **⚠WARNING**

**Motorcycle operation with insufficient, deteriorated, or contaminated oil causes accelerated wear and may result in seizure of the pinion and ring gears. Seizure can lock the rear wheel and skid the rear tire, with consequent loss of control.**

### *Oil Level Inspection*

- Have a helper hold the motorcycle vertical on level ground.
- Remove the filler cap.

### **CAUTION**

**Be careful not to allow any dirt or foreign materials to enter the gear case.**

- Check the oil level. If it is low, add oil as necessary. The oil level should come to the bottom thread of the filler opening with the motorcycle held vertical on level ground.

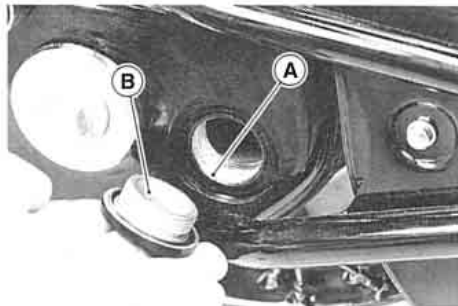

**A. Bottom Thread**

**B. Filler Cap**



## NOTE

- *Use the same type and brand of oil that is already in the final gear case.*

### Oil Change

## NOTE

- *Final gear case oil drains easily and picks up any sediment when the oil is warmed up by running the motorcycle.*
- Put the motorcycle on its side stand.
- Place an oil pan beneath the gear case.

- Remove the filler cap and drain plug.

## ▲WARNING

**Gear case oil is a toxic substance. Dispose of used oil properly. Contact your local authorities for approved disposal methods or possible recycling.**

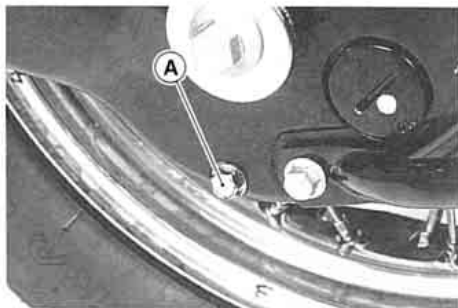

**A. Drain Plug**

**⚠ WARNING**

**When draining or filling the gear case, be careful that no oil gets on the tire, rim, and brake disc. Clean off any oil that inadvertently gets on them with soap and water.**

- After the oil has completely drained out, install the drain plug and gasket. Replace the damaged gasket with a new one.
- With the motorcycle held vertical on level ground, fill the gear case up to the bottom thread of the filler opening with the oil specified below.

Final Gear Case Oil

|              |   |
|--------------|---|
| Oil Capacity | about 200 mL<br>(0.21 US qt)  |
| Oil Type     | API "GL-5"<br>Hypoid gear oil<br>above 5°C (41°F) SAE 90<br>below 5°C (41°F) SAE 80 |

**NOTE**

- *"GL-5" indicates a quality and additive rating. "GL-6" rated hypoid gear oils can also be used.*
- Install the filler cap.

## Spark Plugs

The standard spark plug is shown in the table. The spark plugs should be taken out in accordance with the Periodic Maintenance Chart for cleaning, inspection, and resetting of the plug gap.

### *Maintenance*

If the plug is oily or has carbon built up on it, have it cleaned, preferably in a sand-blasting device, and then clean off any abrasive particles. The plug may also be cleaned using a high flash-point solvent and a wire brush or other suitable tool. Measure the gap with a wire-type thickness gauge, and adjust the gap if incorrect by bending the outer electrode. If the spark plug electrodes are corroded or damaged, or if the insulator is cracked, replace the plug. Use the standard plug.

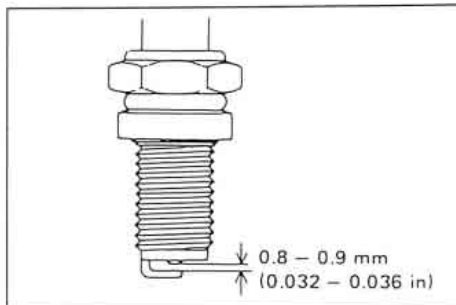

Spark Plug

|                   |                                     |
|-------------------|-------------------------------------|
| Standard Plug     | NGK DPR6EA-9 or<br>ND X20EPR-U9     |
| Plug Gap          | 0.8 ~ 0.9 mm<br>(0.032 ~ 0.036 in.) |
| Tightening Torque | 18 N·m<br>(1.8 kg·m, 13.0 ft·lb)    |

## **Valve Clearance**

Valve and valve seat wear is automatically compensated for the valve clearance. So inspection and adjustment of the valve clearance are not necessary on this motorcycle.

## **Kawasaki Clean Air System**

The Kawasaki Clean Air System (KCA) is a secondary air suction system that helps the exhaust gases to burn more completely. When the spent fuel charge is released into the exhaust system, it is still hot enough to burn. The KCA System allows extra air into the exhaust system so that the spent fuel charge can continue to burn. This continued burning action tends to burn up a great deal of the normally unburned gases, as well as changing a significant portion of the poisonous carbon monoxide into harmless carbon dioxide.

### **Air Suction Valves:**

The air suction valve is essentially a check valve which allows fresh air to flow only from the air cleaner into the exhaust port. Any air that has passed the air suction valve is prevented from returning. Inspect the air suction valves in accordance with the Periodic Maintenance Chart. Also, inspect the air suction valves whenever stable idling

cannot be obtained, engine power is greatly reduced, or there are abnormal engine noises.

Air suction valve removal and inspection should be done by an authorized Kawasaki dealer.

## **Air Cleaner**

A clogged air cleaner restricts the engine's air intake, increasing fuel consumption, reducing engine power, and causing spark plug fouling.

The air cleaner element must be cleaned in accordance with the Periodic Maintenance Chart. In dusty areas, the element should be cleaned more frequently than the recommended interval. After riding through rain or on muddy roads, the element should be cleaned immediately. The element should be replaced if it is damaged.

### *Element Removal*

- Take off the mounting screw on the air cleaner cover located on the left side of the engine and remove the cover from the air cleaner housing.

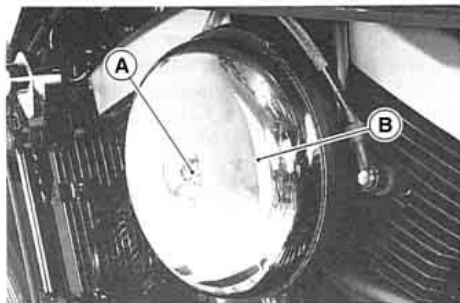

A. Screw

B. Air Cleaner Cover

- Pull the element out of the housing.

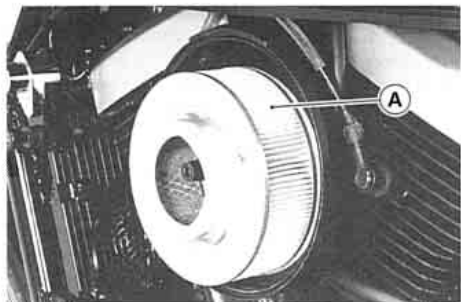

A. Element

- Push a clean, lint-free towel into the butterfly valve intake to keep dirt or other foreign material from entering.
- Inspect the element material and sponge gasket for damage. If any part of the element is damaged, the element must be replaced.

**⚠ WARNING**

If dirt or dust is allowed to pass through into the butterfly valve, the throttle may become stuck, possibly causing accident.

**CAUTION**

If dirt gets through into the engine, excessive engine wear and possibly engine damage will occur.

**NOTE**

○ *Element installation is performed in the reverse order of removal.*

*Element Cleaning*

- Clean the element by tapping it lightly to loosen dust.
- Blow away the remaining dust by applying compressed air from e inside to the outside (from the clean side to the dirty side).

## Throttle Control System

Check the throttle grip play, and the throttle body bores in accordance with the Periodic Maintenance Chart, and adjust the throttle grip play and clean the throttle bores around of the butterfly valves if necessary.

### Throttle Grip:

The throttle grip controls the butterfly valves in the throttle body. If the throttle grip has excessive play due to either cable stretch or maladjustment, it will cause a delay in throttle response, especially at low engine speed. Also, the throttle valve may not open fully at full throttle. On the other hand, if the throttle grip has no play, the throttle will be hard to control, and the fast idle will be erratic.

#### Inspection

- Check that there is 2 ~ 3 mm (0.08 ~ 0.12 in.) throttle grip play when

lightly turning the throttle grip back and forth.

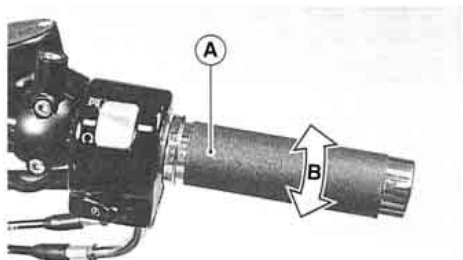

#### A. Throttle Grip

B. 2 ~ 3 mm (0.08 ~ 0.12 in.)

- If there is improper play, adjust it.

#### Adjustment

- Loosen the locknuts at the upper ends of the throttle cables, and screw both throttle cable adjusting nuts in com-



pletely so as to give the throttle grip plenty of play.

- Turn out the decelerator cable adjusting nut until there is no play when the throttle grip is completely closed. Tighten the locknut.

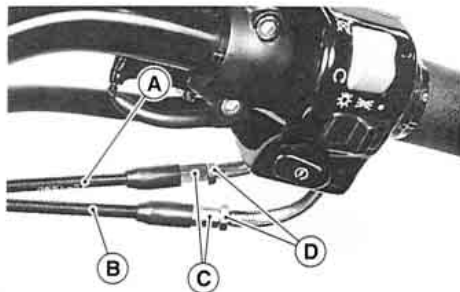

- A. Accelerator Cable
- B. Decelerator Cable
- C. Adjusting Nuts
- D. Locknuts

- Turn the accelerator cable adjusting nut until 2 ~ 3 mm (0.08 ~ 0.12 in.)

of throttle grip play is obtained. Tighten the locknut.

- If the throttle cables cannot be adjusted by using the cable adjusting nuts at the upper ends of the throttle cables, further adjustment should be done by an authorized Kawasaki dealer.

### Throttle Bore Cleaning:

Check the throttle bores at the butterfly valves and around it for carbon deposits.

- Take out the screw in right air cleaner cover, and remove the air cleaner cover.



**A. Right Air Cleaner Cover**  
**B. Screw**

- Wipe any carbon off the throttle bores of the butterfly valves with a lint-free cloth penetrated with a high flash-point solvent on a lint-free cloth.

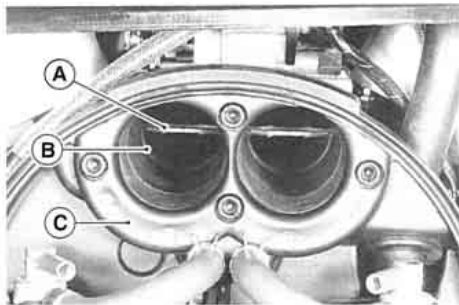

**A. Butterfly Valve**  
**B. Throttle Bore**  
**C. Throttle Body**

## Fast Idle

The fast idle adjustment should be performed in accordance with the Periodic Maintenance Chart or whenever the fast idle is disturbed.

### *Adjustment*

- Start the engine, and warm it up thoroughly.
- Adjust the fast idle to the lowest stable speed by turning the fast idle adjusting screw.

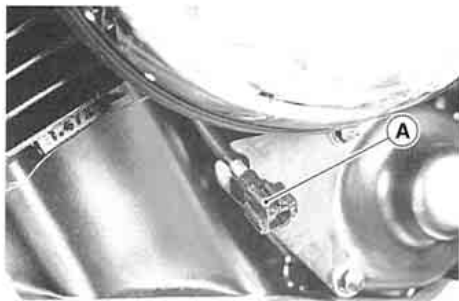

**A. Fast Idle Adjusting Screw**

- Open and close the throttle a few times to make sure that the fast idle does not change. Readjust if necessary.
- With the engine idling, turn the handlebar to each side. If handlebar movement changes the fast idle, the throttle cables may be improperly adjusted or incorrectly routed, or they may be damaged. Be sure to correct any of these conditions before riding.

**⚠ WARNING**

**Operation with damaged cables could result in an unsafe riding condition.**

## Clutch

The motorcycle is equipped with a hydraulically operated clutch that requires no adjustment except fluid level inspection in accordance with the Periodic Maintenance Chart.

### *Fluid Level Inspection*

- The fluid level in the clutch fluid reservoir must be kept above the lower level line (reservoir held horizontal).
- If the fluid level is lower than the line, check for fluid leaks in the clutch line, and fill the clutch fluid reservoir to the upper level line stepped inside it.

## NOTE

- *Use the same fluid as is used in the brakes and keep the same requirements mentioned in the "Brakes" section.*

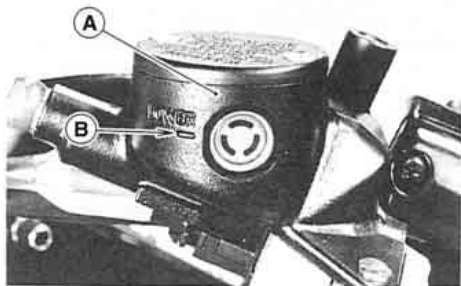

**A. Clutch Fluid Reservoir**  
**B. Lower Level Line**

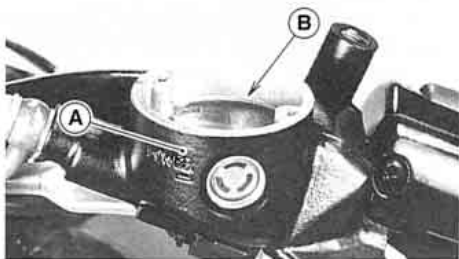

**A. Clutch Fluid Reservoir**  
**B. Upper Level Line**

## Brakes

### *Brake Wear Inspection*

In accordance with the Periodic Maintenance Chart, inspect the brakes for wear. For each front and rear disc brake caliper, if the thickness of either pad is less than 1 mm (0.04 in.), replace both pads in the caliper as a set. Pad replacement should be done by an authorized Kawasaki dealer.

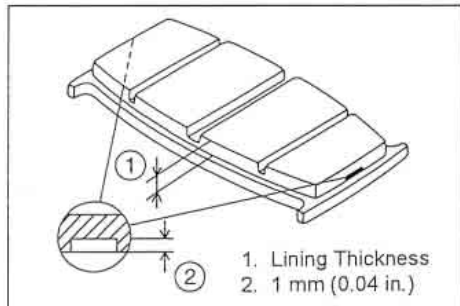

### **Disc Brake Fluid:**

In accordance with the Periodic Maintenance Chart, inspect the brake fluid level in both the front and rear brake fluid reservoirs and change the brake fluid. The brake fluid should also be changed if it becomes contaminated with dirt or water.

### *Fluid Requirement*

Recommended fluids are given in the table below. If none of the recommended brake fluids are available, use extra heavy-duty brake fluid only from a container marked D.O.T. 4.

### Recommended Disc Brake Fluid

|                                |
|--------------------------------|
| Castrol Girling-Universal      |
| Castrol GT (LMA)               |
| Castrol Disc Brake Fluid       |
| Check Shock Premium Heavy Duty |

## CAUTION

Do not spill brake fluid onto any painted surface.

Do not use fluid from a container that has been left open or that has been unsealed for a long time.

Check for fluid leakage around the fittings.

Check brake hose for damage.

### *Fluid Level Inspection*

- The brake fluid level in the front brake fluid reservoir must be kept above the line (lower level line) next to the gauge and that in the rear brake fluid reservoir (located near the brake pedal) must be kept between the upper and lower level lines (reservoirs held horizontal).



A. Front Brake Fluid Reservoir

B. Lower Level Line

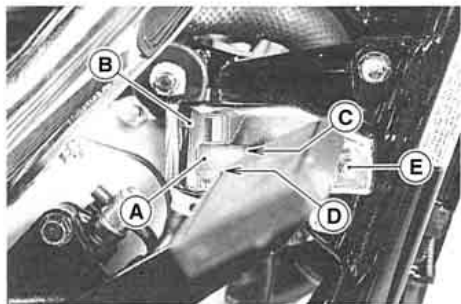

**A. Rear Brake Fluid Reservoir**  
**B. Cover**  
**C. Upper Level Line**  
**D. Lower Level Line**  
**E. Bolt**

- If the fluid level in either reservoir is lower than the lower level line, check for fluid leaks in the brake lines, and fill the reservoir to the upper level line. Inside the front brake fluid reservoir is a stepped line showing the upper level line. For the rear reservoir take off the

bolt and remove the cover from the reservoir.

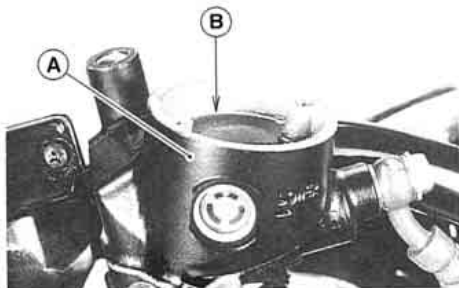

**A. Front Brake Fluid Reservoir**  
**B. Upper Level Line**



**▲WARNING**

Do not mix two brands of brake fluid. Change the brake fluid in the brake line completely if the brake fluid must be refilled but the type and brand of the brake fluid that is already in the reservoir are unidentified.

*Fluid Change*

Have the brake fluid changed by an authorized Kawasaki dealer.

**Front and Rear Brakes:**

Disc and disc pad wear is automatically compensated for and has no effect on the brake lever or pedal action. So there are no parts that require adjustment on the front and rear brakes.

**▲WARNING**

If the brake lever or pedal feels mushy when it is applied, there might be air in the brake lines or the brake may be defective. Since it is dangerous to operate the motorcycle under such conditions, have the brake checked immediately by an authorized Kawasaki dealer.

## Brake Light Switches

When either the front or rear brake is applied, the brake light goes on. The front brake light switch requires no adjustment, but the rear brake light switch should be adjusted in accordance with the Periodic Maintenance Chart.

### *Inspection*

- Turn the ignition key to "ON".
- The brake light should go on when the front brake is applied.
- If it does not, ask your authorized Kawasaki dealer to inspect the front brake light switch.
- Check the operation of the rear brake light switch by depressing the brake pedal. The brake light should go on after about 10 mm (0.4 in.) of pedal travel.

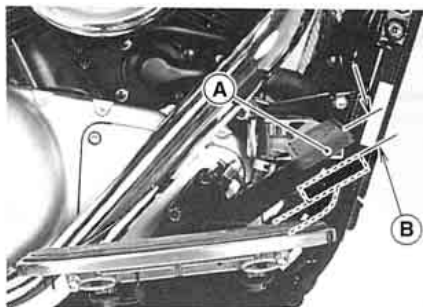

A. Brake Pedal

B. 10 mm (0.4 in.)

- If it does not, adjust the rear brake light switch.

### *Adjustment*

- To adjust the rear brake light switch, move the switch up or down by turning the adjusting nut.

## CAUTION

To avoid damaging the electrical connections inside the switch, be sure that the switch body does not turn during adjustment.

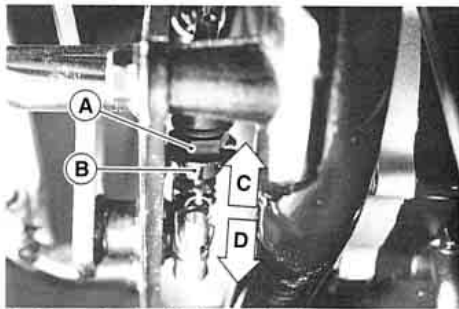

- A. Rear Brake Light Switch
- B. Adjusting Nut
- C. Lights sooner.
- D. Lights later.

## Rear Shock Absorbers (Other than Australian model)

### *Spring Adjustment*

The spring preload adjuster on each rear shock absorber has 5 positions so that the spring can be adjusted for different road and loading conditions.

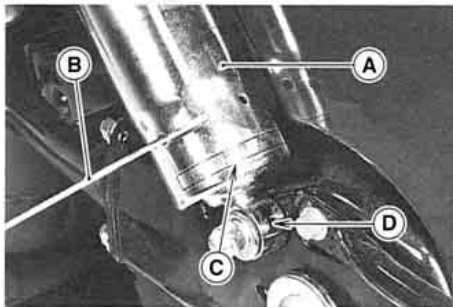

- A. Adjuster
- B. Wrench
- C. Setting Positions
- D. Arrow Mark

If the spring action feels too soft or too stiff, turn each preload adjuster in

accordance with the following table by using the wrench in the tool kit so the desired position mark on the lower end of the adjuster aligns with the arrow mark on the lower end of the shock absorber.

|               |                 |   |   |   |   |
|---------------|-----------------|---|---|---|---|
| Position      | 1               | 2 | 3 | 4 | 5 |
| Spring Action | —————→ Stronger |   |   |   |   |

The standard setting position for an average-build rider of 68 kg (150 lb) with no passenger and no accessories is No. 2.

**▲WARNING**

**If both spring preload adjusters are not adjusted equally, handling may be impaired and a hazardous condition may result.**

**NOTE**

- *Be sure to turn back the adjuster counterclockwise from position 5 when softening the spring action.*

## Wheels

### Tires:

#### *Payload and Tire Pressure*

Failure to maintain proper inflation pressures or observe payload limits for your tires may adversely affect handling and performance of your motorcycle and can result in loss of control. The maximum recommended load in addition to vehicle weight is 180 kg (397 lb), including rider, passenger, baggage, and accessories.

- Check the tire pressure often, using an accurate gauge.



**A. Tire Pressure Gauge**

## NOTE

- *Measure the tire pressure when the tires are cold (that is, when the motorcycle has not been ridden more than a mile during the past 3 hours).*
- *Tire pressure is affected by changes in ambient temperature and altitude, and so the tire pressure should be checked and adjusted when your riding in-*

*volves wide variations in temperature or altitude.*

#### Tire Air Pressure (when cold)

|       |   |   |
|-------|---|---|
| Front | 200 kPa (2.0 kg/cm <sup>2</sup> , 28 psi) |   |
| Rear  | Up to 97.5 kg (215 lb) load               | 250 kPa (2.5 kg/cm <sup>2</sup> , 36 psi) |
|       | 97.5 ~ 180 kg (215 ~ 397 lb) load         | 280 kPa (2.8 kg/cm <sup>2</sup> , 40 psi) |

#### *Tire Wear, Damage*

As the tire tread wears down, the tire becomes more susceptible to puncture and failure. An accepted estimate is that 90% of all tire failures occur during the last 10% of tread life (90% worn). So it is false economy and unsafe to use the tires until they are bald.

- In accordance with the Periodic Maintenance Chart, measure the depth of the tread with a depth gauge, and re-

place any tire that has worn down to the minimum allowable tread depth.

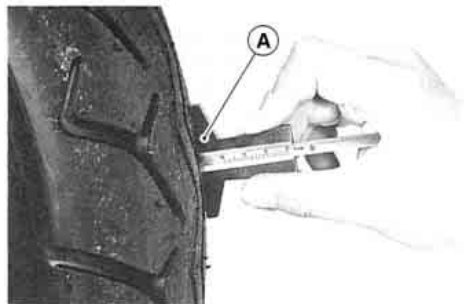

**A. Tire Depth Gauge**

#### Minimum Tread Depth

|       |                         |                 |
|-------|-------------------------|-----------------|
| Front | _____                   | 1 mm (0.04 in.) |
| Rear  | Under 130 km/h (80 mph) | 2mm (0.08 in.)  |
|       | Over 130 km/h (80 mph)  | 3 mm (0.12 in.) |

- Visually inspect the tire for cracks and cuts, replacing the tire in case of bad damage. Swelling or high spots indicate internal damage, requiring tire replacement.
- Remove any imbedded stones or other foreign particles from the tread.

### NOTE

- *Most countries may have their own regulations requiring a minimum tire tread depth; be sure to follow them.*
- *Have the wheel balance inspected whenever a new tire is installed.*

### **▲WARNING**

To ensure safe handling and stability, use only the recommended standard tires for replacement, inflated to the standard pressure.

### NOTE

- *When operating on public roadways, keep maximum speed under traffic law limits.*

### Standard Tire (Tube type)

|       |   |
|-------|---|
| Front | Size: 130/90-16 67H<br>○ DUNLOP "D404FN"<br>○ BRIDGESTONE<br>"EXEDRA G703G" |
| Rear  | Size: 150/80B16 71H<br>○ DUNLOP "D404G"<br>○ BRIDGESTONE<br>"EXEDRA G702G"  |

### **▲WARNING**

Use the same manufacturer's tires on both front and rear wheels.

**⚠ WARNING**

**New tires are slippery and may cause loss of control and injury.**

**A break-in period of 160 km (100 miles) is necessary to establish normal tire traction. During break-in, avoid sudden and maximum braking and acceleration, and hard cornering.**

**Battery**

The battery installed in this motorcycle is a maintenance-free type, so it is not necessary to check the battery electrolyte level or add distilled water.

The sealing strip should not be pulled off once the specified electrolyte has been installed in the battery for initial service.

Since the electrical system of this motorcycle is designed to use only a maintenance-free battery, do not replace it with a conventional battery.

**CAUTION**

**Never remove the sealing strip, or the battery can be damaged.**

**Do not install a conventional battery in this motorcycle, or the electrical system cannot work properly.**



## CAUTION

If you charge the maintenance-free battery, never fail to observe the instructions shown in the label on the battery.

### *Battery Removal*

- Remove the seat.
- Unscrew the battery bracket screw and take off the battery bracket.
- Disconnect the leads from the battery, first from the (-) terminal and then the (+) terminal.

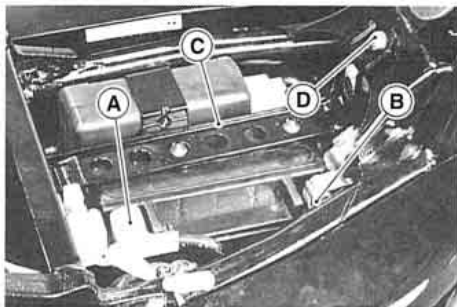

A. (+) Terminal

C. Battery Bracket

B. (-) Terminal

D. Screw

- Pull the battery out of the case.
- Clean the battery using a solution of baking soda and water. Be sure that the lead connections are clean.

### *Battery Installation*

- Connect the capped lead to the (+) terminal, and then connect the black lead to the (-) terminal.
- Put a light coat of grease on the terminals to prevent corrosion.
- Cover the (+) terminal with its protective cap.
- Reinstall the parts removed.

### **Headlight Beam**

#### *Horizontal Adjustment*

The headlight beam is adjustable horizontally. If not properly adjusted horizontally, the beam will point to one side rather than straight ahead.

- Turn the horizontal adjusting screw on the headlight rim in or out until the beam points straight ahead.

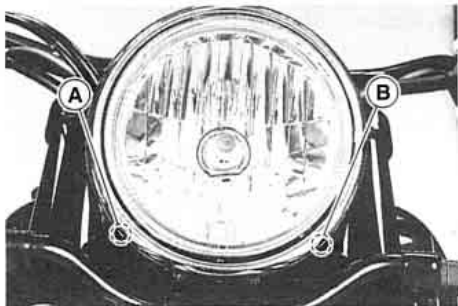

**A. Vertical Adjusting Screw**  
**B. Horizontal Adjusting Screw**

### *Vertical Adjustment*

The headlight beam is adjustable vertically. If adjusted too low, neither low nor high beam will illuminate the road far enough ahead. If adjusted too high, the high beam will fail to illuminate the road close ahead, and the low beam will blind oncoming drivers.

- Turn the vertical adjusting screw on the headlight rim in or out to adjust the headlight vertically.

### **NOTE**

- *On high beam, the brightest point should be slightly below horizontal with the motorcycle on its wheels and the rider seated. Adjust the headlight to the proper angle according to local regulations.*

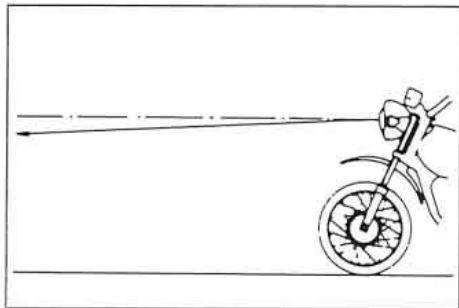

## Fuses

Fuses are arranged in the junction box located on the coolant reserve tank. The main fuse is mounted on the starter relay located behind the coolant reserve tank. The Electronic Control Unit (ECU) is located under the seat. If a fuse fails during operation, inspect the electrical system to determine the cause, and then replace it with a new fuse of proper amperage.

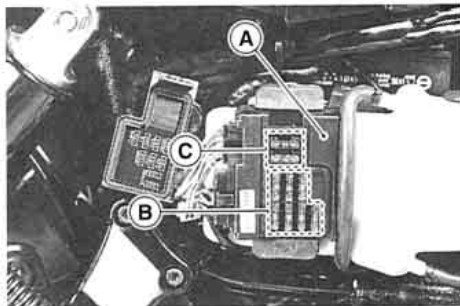

A. Junction Box      C. Spare Fuses  
B. Fuses

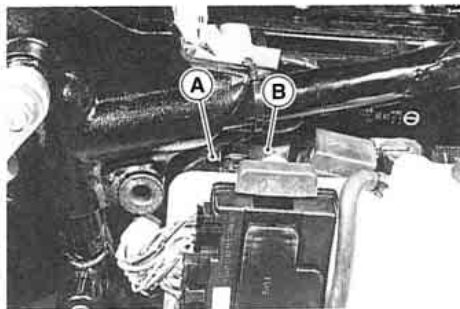

A. Main Fuse      B. Starter Relay

### **⚠WARNING**

Do not use any substitute for the standard fuse.

Replace the blown fuse with a new one of the correct capacity as specified on the junction box and main fuse.

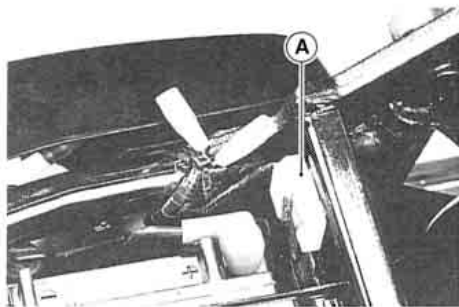

**A. ECU Fuse**

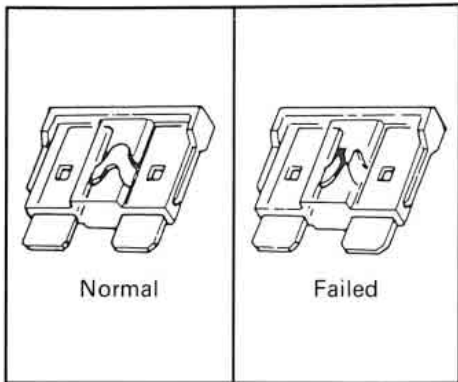

## Cleaning

For the prolonged life of your motorcycle, wash it down immediately after it has been splashed with seawater or exposed to the sea breeze; operated on rainy days, rough roads, or in dusty areas; or operated on roads on which salt has been scattered for ice removal.

### *Preparations for Washing*

Before washing, these precautions must be taken to keep water off the following places:

- Rear opening of muffler – Cover with a plastic bag secured with rubber bands.
- Clutch and brake levers, switch housings on the handlebar – Cover with plastic bags.
- Ignition switch – Cover the keyhole with tape.
- Air cleaner intake – Close up the intake with tape, or stuff with rags.

### *Where to be Careful*

Avoid spraying water with any great force near the following places:

- Meter instruments
- Disc brake/clutch master cylinders and calipers
- Under the fuel tank – If water gets into the ignition coils or into the spark plug caps, the spark will jump through the water and be grounded out. When this happens, the motorcycle will not start and the affected parts must be wiped dry.
- Front and rear wheel hubs
- Steering pivot (steering stem head pipe)
- Swingarm pivot

## NOTE

○ *Coin operated, high pressure spray washers are not recommended. The water may be forced into bearings and other components causing eventual failure from rust and corrosion. Some of the soaps which are highly alkaline leave a residue or cause spotting.*

### *After Washing*

- Remove all plastic bags and tape, and clean the air cleaner intake.
- Lubricate pivots, bolts, and nuts.
- Test the brakes before motorcycle operation.
- Start the engine and run it for 5 minutes.

## ⚠ WARNING

**Never wax or lubricate the brake discs. Loss of braking and an accident could result. Clean the discs with an oilless solvent such as trichloroethylene or acetone. Observe the solvent manufacturer's warnings.**





- Remove the empty fuel tank, pour about 250 mL (½ pint) of motor oil into the tank, roll the tank around to coat the inner surfaces thoroughly, and pour out the excess oil.
- Remove the spark plugs and spray fogging oil directly into each cylinder. Push the starter button for a few seconds to coat the cylinder walls. Install the spark plugs.

#### **⚠WARNING**

**Do not lean over the engine when performing this procedure. An air/oil mist may be forcibly ejected from the spark plug holes and could get into your eyes. If you do get some in your eyes, wash your eyes immediately with liberal amounts of clean, fresh water. Consult a physician as soon as possible.**

- Reduce tire pressure by about 20%.
- Set the motorcycle on a box or stand so that both wheels are raised off the ground. (If this cannot be done, put boards under the front and rear wheels to keep dampness away from the tire rubber.)
- Spray oil on all unpainted metal surfaces to prevent rusting. Avoid getting oil on rubber parts or in the brakes.
- Lubricate all the cables.
- Remove the battery, and store it where it will not be exposed to direct sunlight, moisture, or freezing temperatures. During storage it should be given a slow charge (one ampere or less) about once a month. Keep the battery well charged especially during cold weather.
- Tie plastic bag over the muffler to prevent moisture from entering.

- Put a cover over the motorcycle to keep dust and dirt from collecting on it.

**Preparation after Storage:**

- Remove the plastic bags from the muffler.
- Install the battery in the motorcycle and charge the battery if necessary.
- Make sure the spark plugs are tight.
- Fill the fuel tank with fuel.
- Check all the points listed in the Daily Safety Checks section.
- Lubricate pivots, bolts, and nuts.



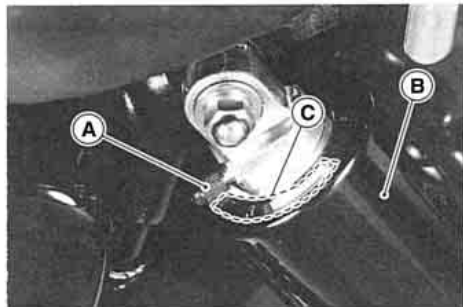

- A. Air Valve
- B. Rebound Damping Force Adjuster
- C. Number

- Check the air pressure with the air pressure gauge.

### NOTE

- *Do not use tire gauges for checking air pressure. They may not indicate the correct air pressure because of air leaks that occur when the gauge is applied to the valve.*

- To lower the air pressure, push the valve core in slightly. To raise the pressure, inject air through the valve with a tire pump. Change the air pressure within the range specified in the preceding table to suit various riding conditions.

### CAUTION

**Inject air little by little so that air pressure does not rise rapidly. Air pressure exceeding 500 kPa (5.0 kg/cm<sup>2</sup>, 71 psi) may damage the oil seal. Try to set the air pressure of the left and right shock absorbers as equally as possible.**

### **⚠WARNING**

**Be sure to adjust the air pressure within the usable range. Pressure too high can produce a hazardous riding condition.**

**Only air or nitrogen gas can be used. Never inject oxygen or any kind of explosive gas. Do not incinerate the rear shock absorber.**

#### *Rebound Damping Force*

The rebound damping force adjuster on each rear shock absorber has 4 positions so that the rebound damping force can be adjusted for different road and loading conditions. The numbers on the adjuster show the setting position.

The following table shows an example of damping force adjustment. To obtain stable handling and a suitable ride, adjust the damping force as indicated. The damping force can be left

soft for average riding. But it should be adjusted harder for high speed riding or riding with a passenger. If the damping feels too soft or too stiff, adjust it in accordance with the following table.

The standard setting position under the same conditions as in air pressure adjustment is No. 2.



#### **To adjust the damping force:**

- Turn the adjusters to the desired position until you feel a click.
- Check to see that both adjusters are turned to the same relative position.

### **⚠WARNING**

**If both damping force adjusters are not adjusted equally, handling may be impaired and a hazardous condition may result.**

## Rebound Damping Force Adjustment

| Adjuster Position | Damping Force   | Setting   | Load  | Road  | Speed |      |
|-------------------|---|---|-------|-------|-------|------|
| 1                 | <br>Stronger | Soft  | Light | Good  | Low   |      |
| 2                 |   |  | Hard  | Heavy | Bad   | High |
| 3                 |   |   |       |       |       |      |
| 4                 |   |   |       |       |       |      |



**VN1500-J1**



**KAWASAKI HEAVY INDUSTRIES, LTD.**  
Consumer Products & Machinery Group

**Part No.99922-1929-02**

Printed in Japan